

# 9400

DZR Brass Metering Station



Via Circonvallazione, 10  
13018 Valduggia (VC), Italy  
Tel: +39 0163 47891  
Fax: +39 0163 47895  
www.vironline.com



DZR brass metering station

Threaded M/F ISO 7/1 Rp (F side threaded ISO 228/1 on DN15 and DN20)

Olive and nut kit (O/N) for European copper tubing (EN1057, F side only) on request:

- DN15, kit for 15mm pipe
- DN20, kit for 22mm pipe

Design according to BS7350

Tolerance on nominal  $K_{vs} \pm 3\%$  (test according to BS7350)

TR CU 010 compliant

PN25 (Max 25bar up to 110°C, max 20bar above)

PN16 with O/N kit (Max 16bar up to 30°C, max 5bar at 120°C)

Free of CE marking (cat. according to Art. 4.3 Dir. 2014/68/EU)

Working conditions

- Suitable for: water, -10°C to +130°C (120°C with O/N kit)  
below 0°C only for water with added antifreeze fluids  
over 100°C only for water with added anti-boiling fluids  
(Glycolic-Ethylene and glycolic-propylene mixtures up to 50% may be used)
- Not suitable for: gases group 1 & 2, liquids group 1 (Dir. 2014/68/UE)

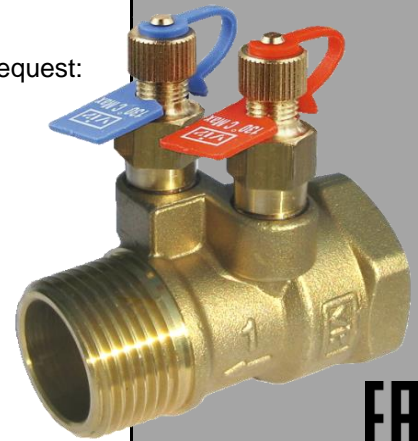

EAC

## PARTLIST

N.	Part	Material	Norm
1	Body	DZR Brass	EN12164 CW602N
2	Venturi insert	DZR Brass	EN12165 CW602N
3	Test point	DZR Brass <sup>1</sup>	EN12164 CW602N

<sup>1</sup>Test points with EPDM gaskets and polypropylene ties

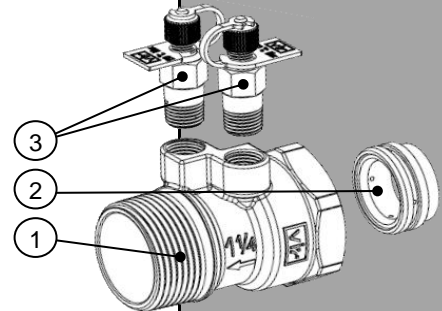

## DIMENSIONS

DN	G <sup>1</sup>	H [mm]	L [mm]	BF [mm]	BM [mm]	I [mm]	Weight [g]	Flow [l/s]
X 015	½"	57,2	60,0 <sup>2</sup>	17,5	15,2	22	219 <sup>2</sup>	0,0075-0,023
U 015	½"	57,2	60,0 <sup>2</sup>	17,5	15,2	22	219 <sup>2</sup>	0,017-0,045
L 015	½"	57,2	60,0 <sup>2</sup>	17,5	15,2	22	217 <sup>2</sup>	0,031-0,074
015	½"	57,2	60,0 <sup>2</sup>	17,5	15,2	22	213 <sup>2</sup>	0,062-0,148 <sup>4</sup>
020	¾"	60,0	62,0 <sup>3</sup>	19,0	16,5	22	254 <sup>3</sup>	0,138-0,325 <sup>4</sup>
025	1"	63,5	67,6	22,5	19,1	22	353	0,258-0,603 <sup>4</sup>
032	1¼"	69,0	72,4	24,8	21,4	22	463	0,540-1,250 <sup>4</sup>
040	1½"	72,0	72,4	24,8	21,4	22	531	0,810-1,880 <sup>4</sup>
050	2"	78,0	82,0	29,2	25,7	22	755	1,520-3,510 <sup>4</sup>

<sup>1</sup>ISO7/1 Rp (F side threaded ISO 228/1 on DN15 and DN20)

<sup>2</sup>For olive and nut version length 70,7mm, weight +31g

<sup>3</sup>For olive and nut version length 73,7mm, weight +37g

<sup>4</sup>Suggested flow range applicability (BS7350).

If used with measuring manometers different from those proposed by VIR please verify that sensibility of the measuring device is compatible with indicated minimum flow (see flow measurement paragraph)

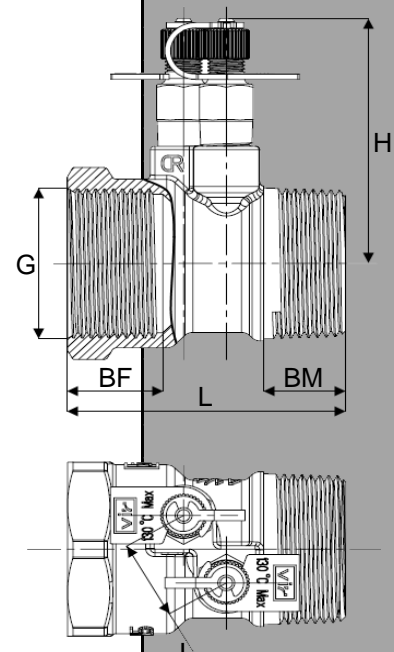

170306

## FLOW MEASUREMENT

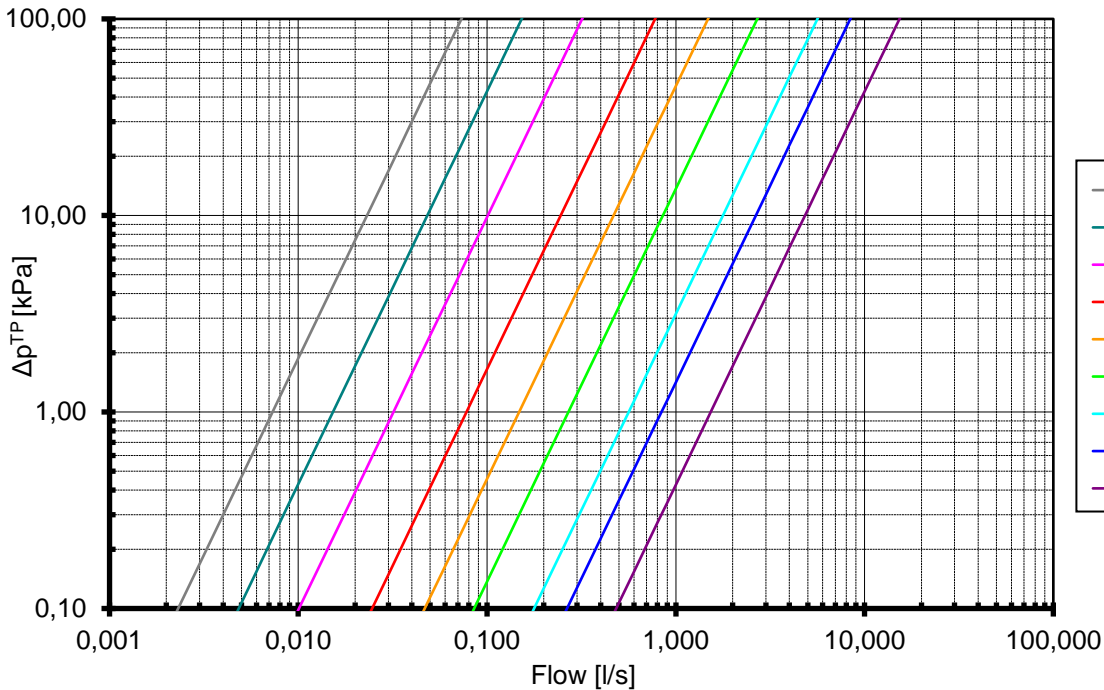

Formula linking flow  $Q$  (in l/s) and  $\Delta p$  measured at test points (in kPa).  
Minimum flow that can be measured for each diameter may be calculated by using in the formula minimum  $\Delta p$  that can be measured by used manometer.  
Valves are anyway designed for best performances when used on range previously suggested and as indicated by BS7350.

$$Q = \frac{K_{vs}^{venturi} \cdot \sqrt{\Delta p^{TP}}}{36}$$

High pressure test point  
Low pressure test point

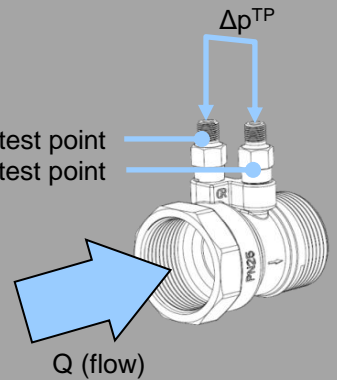

## HEADLOSS CALCULATION

DN	$K_v$ [m <sup>3</sup> /h]
X 015	0,25
U 015	0,61
L 015	1,23
015	3,63
020	7,56
025	13,61
032	30,78
040	48,10
050	85,51

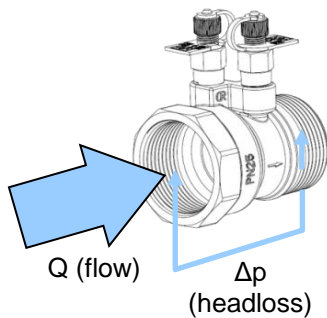

Formula linking flow  $Q$  (in l/s) and theoretical valve headloss  $\Delta p$  (in kPa).

$$\Delta p = \left( \frac{36 \cdot Q}{K_v} \right)^2$$

## INSTALLATION

To obtain the best performances valve must be installed on a pipe with its same nominal size preceded and followed by straight pipe lengths as per figure indications.

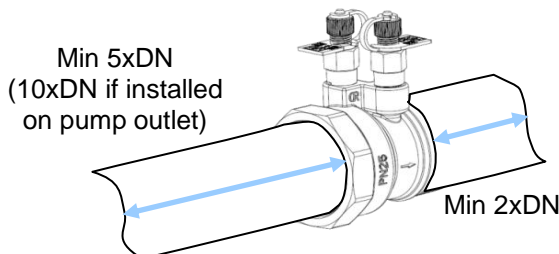

Via Circonvallazione, 10  
13018 Valduggia (VC), Italy  
Tel: +39 0163 47891  
Fax: +39 0163 47895  
www.vironline.com